

COUNTER / TIMER GUIDE

Thank you for purchasing Autonics product.

Before use, be sure to read the safety considerations and use them correctly.

Autonics

CONTENTS

Selecting Counters / Timers	3
What is a Counter?	4
Glossary and Functions	4
Input / Output	4
What is a Timer?	5
Glossary and Functions	5
Error	5
Contact Configuration	6
APPENDIX	

Selecting Counters / Timers

It is an element to select a counter / timer. Select the right product for each element for the most optimal detection.
You can check the details by referring to the contents.

1 Purpose of use Product selection according to the intended use

Conter, Timer, Counter / Timer

2 Size Select the size of the Counter / Timer

W × H: 48 × 24

48 × 48 (S size)

72 × 36 (Y size)

72 × 72 (M size)

48 × 96 (H size)

21.5 × 28

38.5 × 42.5

3 Power type Select the power type of the Counter / Timer

VDC=: 12, 24, 100 / 110, 24 - 48, 24 - 240

VAC~: 24, 110, 220, 100 - 120, 100 - 240, 24 - 240, 200 - 240

Built-in battery (CR2477)

4 Output Select the output of the Counter / Timer

1-stage setting, 2-stage setting, Indicator

5 Control output Select the control output of the Counter / Timer

Relay, NPN open collector

6 Output operation mode Select the output operation mode of the Counter / Timer (counter, counter / timer model only)

1 / 2-stage setting model: F, N, C, R, K, P, Q, A, S, T, D

Indicator model: Total, Hold

7 Output operation mode Select the output operation mode of the Counter / Timer (timer, counter / timer model only)

1 / 2-stage setting model: Signal on delay, Power on delay, Flicker, Interval, Signal off delay, On-Off delay, Integration time, On time display, Star - Delta, Twin

Indicator model: Total, Hold

8 Connection method Select the connection method of the Counter / Timer

Terminal, Socket-plug

What is a Counter?

A counter is a digital logic circuit for processing numerical values with clock pulses.

■ Electronic counter

Each function is a counter consisting mainly of transistors, ICs, micro-computers, etc.

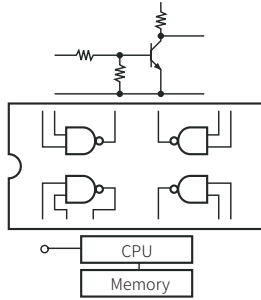

■ Preset counter

A counter whose control output operates when it counts up to a setting value.

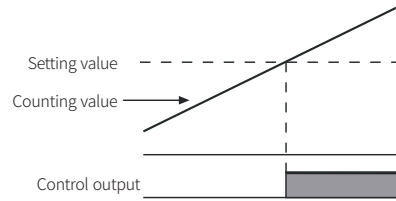

■ Indicator counter (= Total counter)

A counter which indicates the total value of the counting inputs is not provided with a control output.

Glossary and Functions

■ Pulse

An wave that has repetitive and temporal changes of its level.

■ Count

Counting the number of pulses.

■ Miss count

A state that number of pulses and counted is not matched.

■ CPS: Count Per Second

Unit of counts per second that express counting speed.

■ Duty ratio

It is the ratio of the ON time and OFF time of the counting input signal.

The maximum counting speed of each counter is the counting speed when the duty ratio is 1:1.

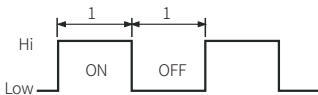

■ Maximum counting speed

The maximum counting speed at which the output section of the counter operates accurately without miscounting when input signal with duty ratio is 1:1. The counting speed is expressed in units of counts per second (CPS).

■ Zero blanking

A function that removes unnecessary "zero" on display so that users do not have to be confused when reading display.

- E.g.) When 123 is being displayed
Display with zero blanking function applied: 123
Display without zero blanking function: 0123

■ Memory protection

A function that restores data counted until right before the main power is cut off and shows it on the display when having power source back.

■ Reset

To restore the counting, display and output sections of the counter, to their initial states.

- Manual reset
: Press the Reset button on the front of the counter to return to the initial state.
- Power reset
: To reset the counter by cutting off the operating supply voltage.
- External reset
: To reset the counter by applying a specific signal to the reset input signal terminal.
- Automatic reset
: To reset the counter automatically with a signal generated from inside the counter.
- Reset signal width
: Min. reset signal width to reset by power off or by applying external (manual) reset signal.

Input / Output

■ Input

If the signal width of either ON or OFF is narrower than regular, it may not be counted as a signal.

- E.g.) Maximum counting speed is 2 kcps

$$\text{Cycle} = \frac{1}{2 \text{ kHz}} = 0.5 \text{ ms}$$

Thus, signal width of ON and OFF should be at least over 0.25 ms.

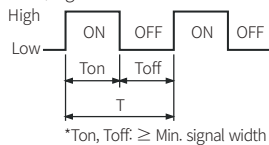

Input counting speed [cps]	ON or OFF time [sec]
1	0.5
30	16.7 m
2 k	0.25 m
5 k	0.1 m
7 k	0.07 m
10 k	0.05 m

• Non-voltage input

: A way that counter receiving input signal from input terminal (cp1, cp2) when whose electric potential phase is turning "High" to "Low".

• Voltage input

: Electric potential is applied through input terminal (cp1, cp2), and counter receives input signal when electric potential phase is turning "Low" to "High".
High: 5 - 30 VDC, Low: ≤ 2 VDC

• Solid state input signal

: Input signal generated by transistors of semiconductor circuit (proximity sensor, photo sensor, rotary encoder, fiber optic sensor, etc.).

• Contact input signal

: Contact input signal generated by micro switch, relay, push button, etc.
Set max. counting speed 1 or 30 cps to use relay contact signal as input signal source.

■ Output

• Count up

: A state that output part started operation after counted value reaching to SV.

• Retained output

: Output status that starts operation once counted value reaches SV, and maintains producing output signal until reset signal applied.

• One-shot output

: After counting up, operating output for one-shot time period, returning back to its old position.
Set the time volume on the front or select the output operation time in the setting mode.

• Solid state output

: An output signal that generated by transistors.

• NPN open collector output

: The solid state output which is open between collector of transistor and +V power terminal.

• Allowable inflow current

: The maximum permissible limit of current that transistor can stand with when load is connected to SSR. (≤ 100 mA)

• Allowable voltage

: The maximum allowable voltage that is receivable for transistor to operate itself when load is connected to SSR (≤ 30 VDC)

• Relay contact output

: Output signal generated by built-in relay contactor inside counter.

What is a Timer?

It is a controller that outputs when a set time elapses after receiving a signal.

Glossary and Functions

■ ON time

The period of time during a required voltage is being applied to the timer or start signal.

■ OFF time

The period of time between the moment that resetting begins and the moment that the operating voltage is applied to the operating circuit. (> resetting time)

■ Operating time

The period of time from ON time to the time convert b-contact to a-contact.

■ Holding time

The period of time from temporary b-contact acts to return.

■ Resetting time

It is the time it takes to return to the state before use when the timer is running or the power is cut off after the operation is completed.

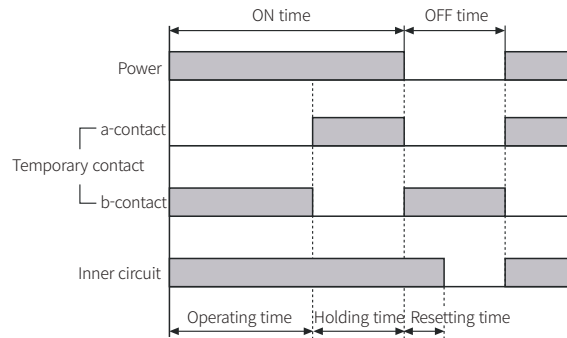

Time temporary work chart

Resetting time is indicated on the specification of each series. When the timer is operated less than indicated OFF time, the timer running time will be short or will not work.

Therefore, OFF time should be longer than resetting time.

■ Self-reset: Power reset

Turn off the power to reset.

■ Electrical reset

To reset timer by applying a required voltage to the reset circuit.

■ Manual reset

To mechanically reset the timer by manual operation.

Error

Hour timer is represented by 5 articles, repeat error (imbalance of operating time), setting error, influence of voltage, OFF time characteristics, and influence of temperature.

But, sometimes almost unaffected items are not listed in the individual specifications.

- TMs: Timer's maximum setting time (TMs is a set value in the case of a digital timer)

■ Repeat error

Error occurs when after set at random times, repeat an action under the same conditions.

The formula below is used to calculate the repeat error, and the number of measurements should be 5 or more.

$$\text{Repeat error} = \pm \frac{1}{2} \times \frac{T_{\max} - T_{\min}}{T_{\text{Ms}}} \times 100 (\%)$$

- T_{max}: Maximum value of operating times measured at the same time
- T_{min}: Minimum value of operating times measured at the same time

■ Setting error

Difference between the actual operation time and scale time.

Measurement position can be any position as long as it is set to 1/3 min. of the maximum scale time.

$$\text{Setting error} = \pm \frac{TM - TS}{T_{\text{Ms}}} \times 100 (\%)$$

- TM: Average value of measured times (min. 5 times)
- TS: Set time (any scale time)

■ Influence of voltage

Fluctuation range about operating time when the current of operating power is fluctuating within allowable current fluctuation range.

$$\text{Influence of voltage} = \pm \frac{TM \times 1 - TM1}{T_{\text{Ms}}} \times 100 (\%)$$

- TM × 1: The average current time when the TM1 deviation is maximum within allowable voltage fluctuation range.
- TM1: Average value of operating times at rated voltage.

■ OFF time characteristics

A change in operating time when the operating time is a given OFF time are changed.

OFF time characteristics are determined by the charging and discharging of a capacitor and resistor used in combination as an electronic timer. The characteristics vary by ± 1.5 to ± 5 %.

$$\text{OFF time characteristics} = \pm \frac{TM \times 3 - TM3}{T_{\text{Ms}}} \times 100 (\%)$$

- TM × 3: Average value of operating times measured with an OFF time that causes the maximum deviation from TM3 within the specified OFF time range of 1 hour from the specified setting time.
- TM3: Average value of operating times measured with 1 second OFF time

■ Influence of temperature

It converts and displays the effect that the change of temperature affects to the operating time in the range of the ambient temperature to the change of operating time.

$$\text{Influence of temperature} = \pm \frac{TM \times 2 - TM2}{T_{\text{Ms}}} \times 100 (\%)$$

- TM × 2: Average value of operating time measured at a temperature which causes the maximum deviation from TM2 within the ambient temperature range.
- TM2: Average value of operating times measured at 20 °C.

Contact Configuration

Title	Symbol	Discription
SPST (1a) : Single Pole Single Throw		Organized one COM and one a-contact or b-contact.
SPST (1b) : Single Pole Single Throw		
SPDT (1a1b) or SPDT (1c) : Single Pole Double Throw		Organized one COM and one a-contact and one b-contact.
DPST (2a) : Double Pole Single Throw		Organized two COMs and two a-contact or b-contact.
DPST (2b) : Double Pole Single Throw		
DPDT (2a2b) or DPDT (2c) : Double Pole Double Throw		Organized two COMs and two a-contact and two b-contact.

■ Symbols at internal connection diagram

Title	Symbol	Discription
a-contact		Normally open contact when no relay input is applied.
b-contact		Normally closed contact when no relay input is applied.
c-contact		a-contact and b-contact are contacted at one line. b-contact is located right hand side or up side.
Time-limit operation		① = a-contact ② = b-contact
Manually operation		Automatic returning contact = display push button switch control contact, ① = a-contact ② = b-contact
Relay		Electromagnetic relay
LED		Used to indicate the operating state of the timer.

APPENDIX

Safety Certification for Product and Component	III
Communication Standards	V
IP Code (protection against dust and water)	VI

Safety Certification for Product and Component

- For detailed certification information, visit the website of each certification body.
- For the status of certification on our product, visit the Autonics website.

■ CE

- Country: European Union



CE marking is the conformity marking, meaning that it complies with all Directives of the Council of European Union regarding safety, health, environmental, and consumer protection standards.

If a product judged to be a risk to the consumer's health, safety, and environmental protection, is sold in the European market, the CE mark must be affixed. It is an essential certification for entry into the European market.

■ UL Listed

- Country: United States



UL listing is the American standard for safety. It is a non-mandatory standard, but most States mandate this standard. This certification is highly favored by consumers.

UL Listed Mark means the end product meets standards of safety.

■ TR CU

- Country: Eurasian Economic Union



The EAC certification is accredited by five member countries of the Eurasian Economic Union (EAEU): Russia, Kazakhstan, Belarus, Armenia, and Kyrgyzstan.

Regulated products without the EAC mark are prohibited to access the markets of 5 members of EAEU.

- Type of certification
: Certificate of Conformity (CoC),
Declaration of Conformity (DoC)

■ KC

- Country: Republic of Korea



The KC certification mark must be affixed on an imported or domestically manufactured electrical product that is to be distributed or sold in Korea.

Type of certification: safety certification, EMC certification

- Safety certification: Korean Agency for Technology and Standards (KATS) affixes and manages the KC certification mark for electrical appliances, household goods, and children's products by dividing the steps into safety certification / safety confirmation / supplier's declaration of conformity (SODC) according to the different levels of potential danger.
- EMC certification: Manufacture, sale, or import for equipment that may cause harm to the radio environment and broadcasting communication network, or that may cause or receive significant electromagnetic interference, the KC certification mark is issued through electromagnetic compatibility (EMC) testing.

■ S-Mark

- Country: Republic of Korea



The S-Mark is the optional certification system to prevent industrial accidents. Korea Occupational Safety and Health Agency (KOSHA) conducts a comprehensive evaluation for the safety and reliability of product, and the capability of quality control in manufacturing.

Due to non-mandatory, there is no regulation or disadvantage on the uncertified product.

■ UL Recognized

- Country: United States



UL listing is the American standard for safety. It is a non-mandatory standard, but most States mandate this standard. This certification is highly favored by consumers.

UL Recognized Mark means the components intended for use in a complete product or system meet standards of safety.

■ KCs

- Country: Republic of Korea



The Minister of Employment and Labor evaluates the safety of hazardous or dangerous machinery, equipment, facilities, protective devices, and protective equipment based on the 'safety certification standards.' Occupational Safety and Health Agency (Ulsan, in South Korea) certifies safety through comprehensive tests complying with the 'safety certification standards.'

Any person who intends to manufacture, import, or change major structural parts of products subject to safety certification, must obtain this certification.

■ TUV NORD

- Country: Germany



TUV is a leading German private certification body that has been responsible for many testing and certification tasks related to safety in the industry for a long time. It is intended to protect people and property from fire and other accidents. Currently, TUV is conducting tests and inspections on safety and quality in various industries such as machinery, electronics and electricity, automobiles, chemical facilities, nuclear power, and aircraft. It is voluntary standards, and certification is issued complying with various EU Directives and German safety regulations.

■ Metrology Certification

- Country: Russia



Metrology Certification is a certificate for measuring and test equipment. Registration of measuring equipment is currently being revised and implemented following the Russian Federal Law, and is managed and supervised by the measurement authority, which is the subject of the certification. Measurement authorities review and test measuring equipment to be used in the Russian Federation based on the State System of Measurement (SSM), issue certificates, and manage them in the government's online database for users and buyers to browse.

■ CCC

- Country: China



The China Compulsory Certificate system (CCC) is a compulsory mark for products that met Chinese technical standards and are allowed to be imported by the Chinese government. Foreign-imported industrial products are examined through CCC certification process whether they meet safety standards or not. The certified products are distributed and sold with the CCC mark or factory code according to the product. CCC certification is administered by the China Quality Certification Center (CQC).

■ PSE

- Country: Japan



PSE is a compulsory certification administered by the Ministry of Economy, Trade and Industry (METI) and governs by the Electrical Appliances Safety Law in Japan. The purpose is to minimize the occurrence of harm and damage caused by electrical equipment by regulating the manufacture and sale of electrical appliances and bring an engagement of the private sector to ensure the safety of electrical appliances. Manufacture, import, and sell electrical appliances in the Japanese market, the technical standards for those products must be satisfied and the PSE certification mark must be displayed.

■ GOST

- Country: Russia



GOST is national technical standards set by the Euro Asian Council for Standardization, Metrology and Certification (EASC). The abbreviation GOST stands for GOSudarstvennyy STandart, which means State Union Standard in Russian. The current GOST standard includes over 20,000 titles and is widely used in common in the Commonwealth of Independent States (CIS) (12 countries). All countries of the CIS currently adopt and use the GOST standard, but the certificates issued by each country and the subject of the issuing certification body are different, so each country's GOST certificate can be regarded as a different certificate. The national standards of Russia are the GOST R, those of Kazakhstan are GOST K, etc.

■ China RoHS

- Country: China



China RoHS is the Chinese government regulation to control and eliminate the environmental impact of toxic and hazardous substances and elements in electrical/ electronic equipment. China's Measures for the Administration of the Control of Pollution by Electronic Information Products like the EU RoHS Directive have been enacted, and regulate additional hazardous substances compare to EU RoHS. Marking a logo or label for marking information is mandatory. In addition, there is a certification system before selling the product to ensure its conformity by conducting test analysis. Products to be exported to China will be screened prior to customs entry. Customs entry is only permitted for products that meet conformance standards.

Communication Standards

• For detailed information on communication, visit the related association's website.

■ EtherNet/IP

EtherNet/IP™

EtherNet/IP is an industrial network protocol that conforms Common Industrial Protocol to standard Internet. It is one of the leading industrial protocols in the United States and is widely used in a variety of industries, including factories.

EtherNet/IP and CIP technologies are managed by ODVA, Inc., a global trade and standards development organization founded in 1995 with over 300 corporate members.

EtherNet/IP uses the most widely adopted Ethernet standards - Internet Protocol and IEEE 802.3 - to define functions for the transport, network, data link, and physical layer. CIP uses object-oriented design to provide EtherNet/IP with services and device profiles needed for real-time control and to promote consistent implementation of automation functions across a diverse ecosystem of products.

■ DeviceNet

DeviceNet

DeviceNet is a digital multidrop network to interconnect industrial controllers and I/O devices. DeviceNet provides users a cost-effective network for distribution at no cost, deploys and manages simple devices across the architecture.

DeviceNet uses CAN (Controller Area Network), a network technology used in automobile vehicles, for its data link layer, and this network is used in almost all industries. DeviceNet is approved by CENELEC for its official standard and is also used as a global standard.

■ ProfiNet



PROFINET, designated and announced by PI (PROFIBUS & PROFINET), is the open standard for industrial Ethernet in automation technology. It provides solutions for process automation, factory automation and motion control. It enables the integration of existing fieldbus systems such as PROFIBUS, Interbus and DeviceNet into an open Ethernet-based network. PROFINET, the protocol for communication, configuration and diagnosis in the network, uses Ethernet standard as well as TCP, UDP, IP.

It achieves fast and safe data exchange, enabling the concepts of innovative machine and plant. Thanks to its flexibility and openness, PROFINET offers the users a freedom in building machine and plant architectures and significantly increases plant availability by optimal use of resources available to users.

■ CC-Link



CC-Link is the open field network and the global standard with SEMI certification. As high-speed field network, CC-Link can process both control data and information data at the same time. With a high communication speed of 10 Mbps, it supports a transmission distance of 100 meters and connects to 64 stations.

It achieved high-speed response of up to 10 Mbps, guaranteeing punctuality. With CC-Link, complex production lines can be simplified and built at low cost. There are advantages of reducing the cost of wiring components, shortening the wiring construction period, and improving maintainability.

CLPA provides a memory map profile that allocates data for each product type. CC-Link compatible products can be developed based on this profile, and users can use the same program for connection and control even if existing product is replaced to other vendors' one.

■ EtherCAT

EtherCAT®

EtherCAT (Ethernet for Control Automation Technology) is an Ethernet-based fieldbus system developed by Beckhoff Automation. After releasing the technology from ETG (EtherCAT Technology Group) in 2003, it is standardized in IEC 61158 since 2007. It is a communication method that uses the frame according to IEEE 802.3 and physical layer and is an Ethernet protocol-based automation software that requires low jitter, short cycle time, and reduced hardware cost.

EtherCAT supports almost all topologies which have the advantage of flexibility and user-friendly. Due to the high-speed network, EtherCAT is suitable for applications requiring simultaneous operation.

■ HART



HART is the global standard for digital information communication via analog wires between smart devices and control or monitoring systems.

It is the duplex communication protocol and supports various analog I/O modules with HART connection. It sends and receives digital information through 4-20 mA current. It provides a reliable and long-term solution for plant operators who seek the benefits of smart devices with digital communication while maintaining existing facilities for analog instrumentation and plant wiring. Many sites that have applied the HART protocol can access to many digital process, maintenance and diagnostic information.

■ ProfiBus



ProfiBus is the open standard commonly used for process automation in the production site.

- Configuration
 - Master: It determines data traffic, transmits messages, and performs as role of Active Station.
 - Slave: It means I/O devices, valves, motor drivers, transmitters, etc. Slave receives a message and transmits the message depending on the Master's request.
- Up to 124 slaves and 3 masters can be connected to one communication line, and the communication method uses the half duplex method. Each device is connected to the bus in parallel and each device has its network address, so the installation location is irrelevant. Each device can be moved or removed during the communication.

IP Code (protection against dust and water)

IEC (International Electro-technical Commission) Standard

The IP Codes are defined in the IEC standard 60529.



1 Degree of protection against dust (protected from solid foreign objects)

Numeral	Degree of protection	Degree of protection
0	Non-protected	
1		Protection against the objects with 50 mm diameter or more. The object probe, sphere of 50 mm diameter, must not fully penetrate. - Test means : Rigid sphere without handle or guard. - Test force: 50 N ± 10%
2		Protection against the objects with 12.5 mm diameter or more. The object probe, sphere of 12.5 mm diameter, must not fully penetrate. - Test means : Rigid sphere without handle or guard. - Test force: 30 N ± 10%
3		Protection against the objects with 2.5 mm diameter or more. The object probe, sphere of 2.5 mm diameter, must not fully penetrate. - Test means : Rigid steel rod with edges free from burrs. - Test force: 3 N ± 10%
4		Protection against the objects with 1 mm diameter or more. The object probe, sphere of 1 mm diameter, must not fully penetrate. - Test means : Rigid steel rod with edges free from burrs. - Test force: 1 N ± 10%
5		Protection against the dust with or without pressure. - Dust-protected enclosures allow a limited quantity of dust to penetrate; complete protection against contact. Test duration: 8 hours Dust (the talcum powder) : It must be able to pass a square-meshed sieve that its nominal wire with 50 µm diameter; the nominal width of a gap between wires 75 µm. The amount of talcum powder: 2 kg/m ³
6		Protection against the dust under pressure. - Dust-tight enclosures do not allow any dust to penetrate. Test duration : 2 hours (a volume of dust: 40 to 60 / hour) 8 hours (a volume of dust: less than 40 / hour) Depression : Less than 2 kPa (20 mbar) on the manometer. Dust (the talcum powder) : It must be able to pass a square-meshed sieve that its nominal wire with 50 µm diameter; the nominal width of a gap between wires 75 µm. The amount of talcum powder: 2 kg/m ³

2 Degree of protection against ingress of water (protected from liquids)

Numeral	Degree of protection	Degree of protection
0	Non-protected	
1		Protection against vertically falling water drops. Water drops flow over the whole area of four sides on a fixed and tilting enclosure. - Test duration : 10 min (2.5 min in each of four sides)
2		Protection against vertically falling water drops when the enclosure is tilted up to 15° from its normal position. Uniform flow of water drops over the whole area of the enclosure. - A rotation speed of turntable: 1r / min - Test duration: 10 min
3		Protection against spraying water at an angle up to 60° on either side of the vertical. The oscillating tube has spray holes over an arc of 60° either side of the center point. It sprinkles through an angle of 120° and 60° on either side of vertical. Then, the enclosure is turned through a horizontal angle of 90°, and continue the test for 5 min. - Test duration : 10 min (5 min in each of sides) - Mean flow rate per hole: 0.07 L/min
4		Protection against splashing water from any direction. - No harmful effects on the product. The oscillating semicircle tube with spray holes sprinkles through an angle of 360°. - Test duration: 10 min - Mean flow rate per hole: 0.07 L/min
5 ⁰¹⁾		Protection against projecting water in jets from any direction. - No harmful effects on the product. Spraying a stream of water from the test nozzle (internal diameter: Ø 6.3 mm) at all directions. - Test duration: 3 min - Distance from nozzle to enclosure surface : 2.5 to 3 m - Delivery rate: 12.5 L/min ± 5%
6 ⁰¹⁾		Protection against powerfully projecting water in jets from any direction. - The product is hermetically sealed. Spraying a stream of water from the test nozzle (internal diameter: Ø 12.5 mm) at all directions. - Test duration: 3 min - Distance from nozzle to enclosure surface : 2.5 to 3 m - Delivery rate: 100 L/min ± 5%
7 ⁰²⁾		Protection against temporary immersion in water under defined conditions of pressure and time. - The product is hermetically sealed. Immersion in water under defined conditions - Test duration: 30 min - Water level: 1 m
8 ⁰²⁾		Complete protection against continuous immersion in water. - The product is hermetically sealed. Immersion in water under defined conditions. - Test duration: more than 8 hours - Water level: 10 m

01) The degree of protection against spraying does not guarantee the effects of immersion.

02) The degree of protection against immersion does not guarantee the effects of spray.

■ DIN (Deutsche Industrie Normen) Standard

The DIN standard is defined in the DIN 40050-9.

IP 1 2

① Degree of protection against dust (protected from solid foreign objects)

Same as IEC standard

② Degree of protection against ingress of water (under high temperature and high pressure)

Letters	Degree of protection	
9K	Water resistance under high temperature and high pressure	Protection against high-temperature vapor and high-pressure water at all directions. - No harmful effects on the product.

■ JEM (Japan Electrical Manufacturers' Association) Standard

The JEM standard is defined in the JEM 1030.

IP 1 2 3

① Degree of protection against dust (protected from solid foreign objects)

Same as IEC standard

② Degree of protection against ingress of water (protected from liquids)

Same as IEC standard

③ Degree of oil proof / oil resistance

Letters	Degree of protection	
F	Oil proof type	Protection against oil drop and oil powder in all directions - Even if oil penetrates in the product, it operates normally.
G	Oil resistant type	Protection against oil drop and oil powder in all directions - Special coating prevents penetration of oil into the product.

Autonics

www.autonics.com

Dimensions or specifications on this manual are subject to change and some models may be discontinued without notice.